

REMS Titan

Teilverzeichnis

Aktueller Stand
siehe www.rems.de

Spare parts list

Latest version
see www.rems.de

Liste des pièces

Situation actuelle
voir www.rems.de

Elenco dei pezzi

Ultimo aggiornamento
vedi www.rems.de

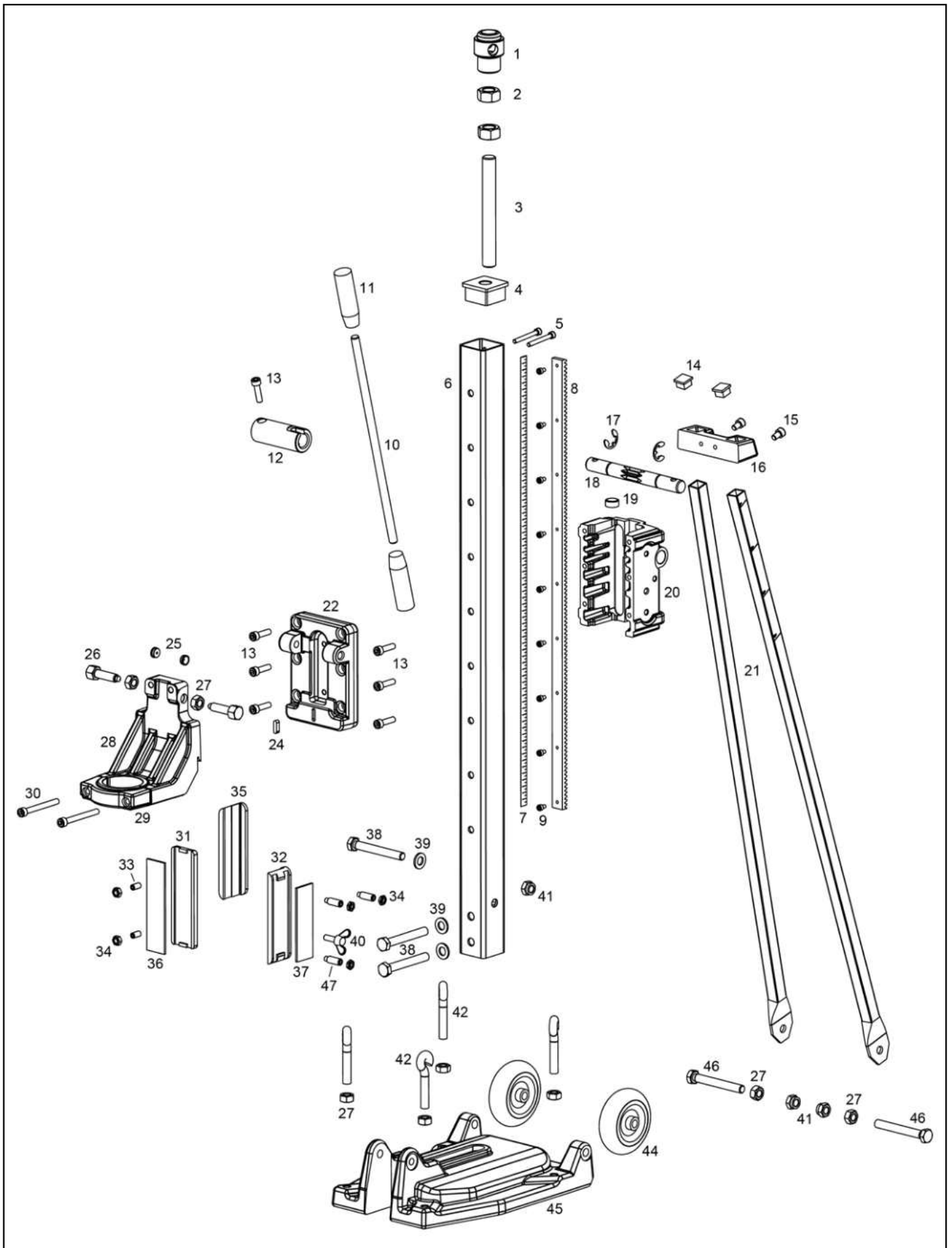

REMS Titan

	deu	eng	fra	ita	
1	Spannkopf	Chuck	Mandrin	Mandrino	183623 R
2	Sechskantmutter	Hexagon nut	Ecrou hexagonal	Dado esagonale	085063
3	Gewindespindel	Threaded spindle	Broche filetée	Perno filettato	183622 R
5	Zylinderschraube	Fillister head screw	Vis à tête cylindrique	Vite a testa cilindrica	081150
—	Führung komplett Pos. 4, 6, 7, 8 und 9	Guiding compl. Pos. 4, 6, 7, 8 and 9	Guidage compl. Pos. 4, 6, 7, 8 et 9	Guida compl. Pos. 4, 6, 7, 8 e 9	183630 R
—	Drehhebel mit Drehhülse kompl. Pos. 10, 11, 12 und 13	Rotating lever with rotating sleeve compl. Pos. 10, 11, 12 and 13	Levier rotatif avec douille rotatif compl. Pos. 10, 11, 12 et 13	Leva rotante con spina rotante compl. Pos. 10, 11, 12 e 13	183651 R
11	Zylinderknopf	Cylinder knob	Bouton cylindrique	Pomello cilindrico	071087
13	Zylinderschraube	Fillister head screw	Vis à tête cylindrique	Vite a testa cilindrica	081145
14	Stopfen	Plug	Bouchon	Tappo a vite	071090
15	Zylinderschraube	Fillister head screw	Vis à tête cylindrique	Vite a testa cilindrica	081149
16	Klemmstück	Clamping piece	Pièce de serrage	Pezzo di serraggio	183639 R
17	Sicherungsscheibe	Lock washer	Rondelle de sécurité	Ranella di sicurezza	059101
18	Ritzelwelle	Pinion shaft	Arbre de pignon	Albero di pignone	183633 R
19	Libelle	Spirit level	Niveau à bulles	Livella a bolla	075125
20	Führungsgehäuse	Guiding case	Carcasse de guidage	Carcassa di guida	183636 R
21	Strebe	Strut	Support	Supporto	183640 R
22	Verschlussplatte	Lock plate	Plaque de verrouillage	Piastra di chiusura	183626 R
24	Passfeder	Spring	Ressort	Molla	062010
25	Buchse	Bush	Douille	Boccola	183656 R
26	Spannbolzen	Clamping bolt	Boulon de serrage	Bullone di serraggio	183645 R
27	Sechskantmutter	Hexagon nut	Ecrou hexagonal	Dado esagonale	085006
—	Spannwinkel komplett Pos. 25, 28, 29 und 30	Clamping angle compl. Pos. 25, 28, 29 and 30	Angle de serrage compl. Pos. 25, 28, 29 et 30	Angolo di serraggio compl. Pos. 25, 28, 29 e 30	183652 R
30	Zylinderschraube	Fillister head screw	Vis à tête cylindrique	Vite a testa cilindrica	081146
31	Führungsleiste	Guiding strip	Barre de guidage	Barra di guida	183644 ROH
32	Führungswinkel 2	Guiding angle 2	Angle de guidage 2	Angolo di guida 2	183643 R
33	Gewindestift	Threaded pin	Vis sans tête	Perno filettato	084082
34	Sechskantmutter	Hexagon nut	Ecrou hexagonal	Dado esagonale	085031
35	Führungswinkel 1	Guiding angle 1	Angle de guidage 1	Angolo di guida 1	183646 R
36	Einstellblech	Adjusting plate	Plaque d'ajustement	Coperchio di regolazione	183650 R
37	Einstellblech	Adjusting plate	Plaque d'ajustement	Coperchio di regolazione	183649 R
38	Sechskantschraube	Hexagon screw	Hexagon vis	Vite esagonale	080036
39	Scheibe	Washer	Rondelle	Disco	086005
40	Flügelgriff	Wing handle	Poignée à oreilles	Manopola a farfalla	083203
41	Sechskantmutter	Hexagon nut	Ecrou hexagonal	Dado esagonale	085071
42	Ringschraube	Ring screw	Vis à œil	Vite a occhio	083202
44	Rad-Vollgummi	Wheel of solid rubber	Roue en caoutchouc massif	Ruota in gomma solida	053024
45	Grundplatte	Base plate	Socle de base	Piastra di base	183621
46	Sechskantschraube	Hexagon screw	Hexagon vis	Vite esagonale	080039
47	Gewindestift	Threaded pin	Vis sans tête	Perno filettato	084081