

# REMS Picus S1

## Teilverzeichnis

Aktueller Stand  
siehe [www.rems.de](http://www.rems.de)  
weitere Teile auf Anfrage

## Spare parts list

Latest version  
see [www.rems.de](http://www.rems.de)  
other parts on request

## Liste des pièces

Situation actuelle  
voir [www.rems.de](http://www.rems.de)  
autres pièces sur demande

## Elenco dei pezzi

Ultimo aggiornamento  
vedi [www.rems.de](http://www.rems.de)  
altri ricambi su richiesta

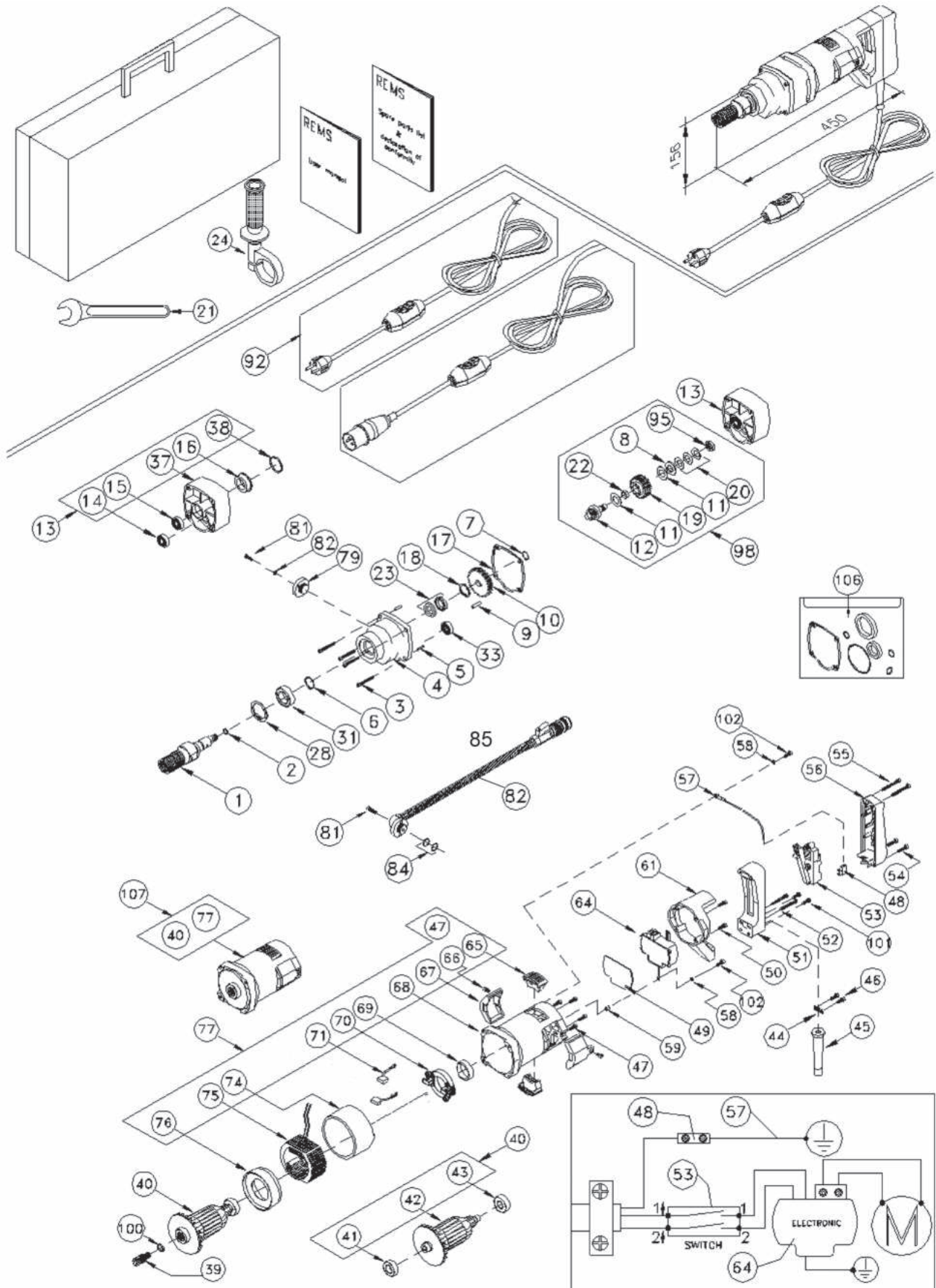

# REMS Picus S1

deu	eng	fra	ita	
1 Antriebsspindel	Drive spindle	Arbre d'entraînement	Mandrino d'azionamento	180190
3 Zylinderschraube	Fillister head screw	Vis tête cylindrique	Vite a testa cilindrica	081144
4 Getriebegehäuse	Gear housing	Carcasse	Scatola ingranaggi	180191
6 Sicherungsring	Locking ring	Circlip	Rondella di sicurezza	059154
7 Sicherungsring	Locking ring	Circlip	Anello di sicurezza	059005
13 Getriebe-Vorderteil	Gear housing front	Carcasse avant	Scatola ingranaggi anteriore	180170
14 Rillenkugellager	Grooved ball bearing	Roulement à billes	Cuscinetto a sfere	057183
15 Rillenkugellager	Grooved ball bearing	Roulement à billes	Cuscinetto a sfere	057005
16 Filzring	Felt ring	Anneau en feutre	Anello feltro	180192
20 Tellerfeder	Cup spring	Ressort Belleville	Molla a disco	061007
21 Einmaulschlüssel SW 32	Spanner SW 32	Clé plate SW 32	Chiave a forcella sempl. SW 32	079002
23 Wellendichtring	Rotary shaft seal	Joint pour arbre	Anello guarnizione ondulata	060312
24 Gegenhalter	Steady	Contre poignee	Maniglia	180167
28 Sicherungsring	Locking ring	Circlip	Rondella di sicurezza	059153
31 Rillenkugellager	Grooved ball bearing	Roulement à billes	Cuscinetto a sfere	057184
38 O-Ring	O-ring	Joint torique	O-ring	060302
39 Ankerritzel	Anchor cog	Pignon	Ruota dentata	180519
40 Anker kompl. mit Lager	Rotor complete with bearing	Induit avec roulement	Indotto completo c. cuscinetto	180513 R220
40 Anker kompl. mit Lager	Rotor complete with bearing	Induit compl avec roulement	Indotto completo c. cuscinetto	180513 R110
43 Rillenkugellager	Grooved ball bearing	Roulement à billes	Cuscinetto a sfere	057064
45 Kabeltülle	Cable bush	Passe-fil	Guaina cavo	180175
49 Isolierfolie	Insulating foil	Film isolant	Pellicola d'isolamento	180505
— Motorgriff komplett Pos. 50–52, 54–56, 61 und 101	Motor handle complete Pos. 50–52, 54–56, 61 and 101	Poignée complète Pos. 50–52, 54–56, 61 et 101	Impugnatura motore completa Pos. 50–52, 54–56, 61 e 101	180501
53 Schalter	Switch	Interrupteur	Interruttore	180502
64 Elektronik	Electronic	Electronique	Elettronica	180504 R220
64 Elektronik	Electronic	Electronique	Elettronica	180504 R110
— ab Maschinenummer 003412 Motorgriff komplett Pos. 50–52, 54–56, 61 und 101	from machine number 003412 Motor handle complete Pos. 50–52, 54–56, 61 and 101	à partir de la machine n° 003412 Poignée complète Pos. 50–52, 54–56, 61 et 101	da matricola 003412 Impugnatura motore completa Pos. 50–52, 54–56, 61 e 101	180131 R
53 ab Maschinenummer 003412 Schalter	from machine number 003412 Switch	à partir de la machine n° 003412 Interrupteur	da matricola 003412 Interruttore	180132 R
64 ab Maschinenummer 003412 Elektronik	from machine number 003412 Electronic	à partir de la machine n° 003412 Electronique	da matricola 003412 Elettronica	180133 R220
64 ab Maschinenummer 003412 Elektronik	from machine number 003412 Electronic	à partir de la machine n° 003412 Electronique	da matricola 003412 Elettronica	180133 R110
65 Lüftungsdeckel	Venting cover	Couvercle ventilateur	Coperchio ventilatore	180508
66 Linsenschraube	Oval head screw	Vis tête fraisée bombée	Vite a testa svasata con perno	083128
67 Deckel	Cover	Couvercle	Coperchio	180516
69 Dämmring	Insulating ring	Anneau isolant	Anello isolante	180518
70 Kohlehalter mit Feder	Carbon holder plate w. spring	Support balais avec ressort	Portacarboncini con molla	180204
71 Kohlebürsten Paar	Carbon brushes pack of 2	Balais de charbon, jeu 2p.	Carboncini, conf. 2 pz.	180511 R220
75 Stator	Stator	Stator	Statore	180526 R220
77 Motorgehäuse kompl.	Motor housing complete	Carcasse moteur compl.	Alloggiamento motore compl.	180517 R220
77 Motorgehäuse kompl.	Motor housing complete	Carcasse moteur compl.	Alloggiamento motore compl.	180517 R110
79 Deckel	Cover	Couvercle	Coperchio	180179
81 Zylinderschraube	Fillister head screw	Vis tête cylindrique	Vite a testa cilindrica	081007
84 O-Ring	O-ring	Joint torique	O-ring	060303
85 Wasserzuführinrichtung Pos. 81, 82, 83	Water connecting device Pos. 81, 82, 83	Dispositif d amenée d'eau Pos. 81, 82, 83	Disp. alimentazione acqua Pos. 81, 82, 83	180169
92 Anschlussleitung 230 V	Connecting cable 230 V	Raccordement 230 V	Cavo d'allacciamento 230 V	030076 R220
98 Rutschkupplung kompl. Pos. 8, 11, 12, 19, 20, 22 und 95	Slipping clutch complete. Pos. 8, 11, 12, 19, 20, 22 and 95	Embrayage complet. Pos. 8, 11, 12, 19, 20, 22 et 95	Frizione completa Pos. 8, 11, 12, 19, 20, 22 e 95	180171
100 O-Ring	O-ring	Joint torique	O-ring	060313
106 Dichtungssatz	Seal kit	Set de joints, jeu	Assortimento guarnizioni, set	180173

## REMS Picus S3

### Teilverzeichnis

Aktueller Stand  
siehe [www.rems.de](http://www.rems.de)  
weitere Teile auf Anfrage

### Spare parts list

Latest version  
see [www.rems.de](http://www.rems.de)  
other parts on request

### Liste des pièces

Situation actuelle  
voir [www.rems.de](http://www.rems.de)  
autres pièces sur demande

### Elenco dei pezzi

Ultimo aggiornamento  
vedi [www.rems.de](http://www.rems.de)  
altri ricambi su richiesta

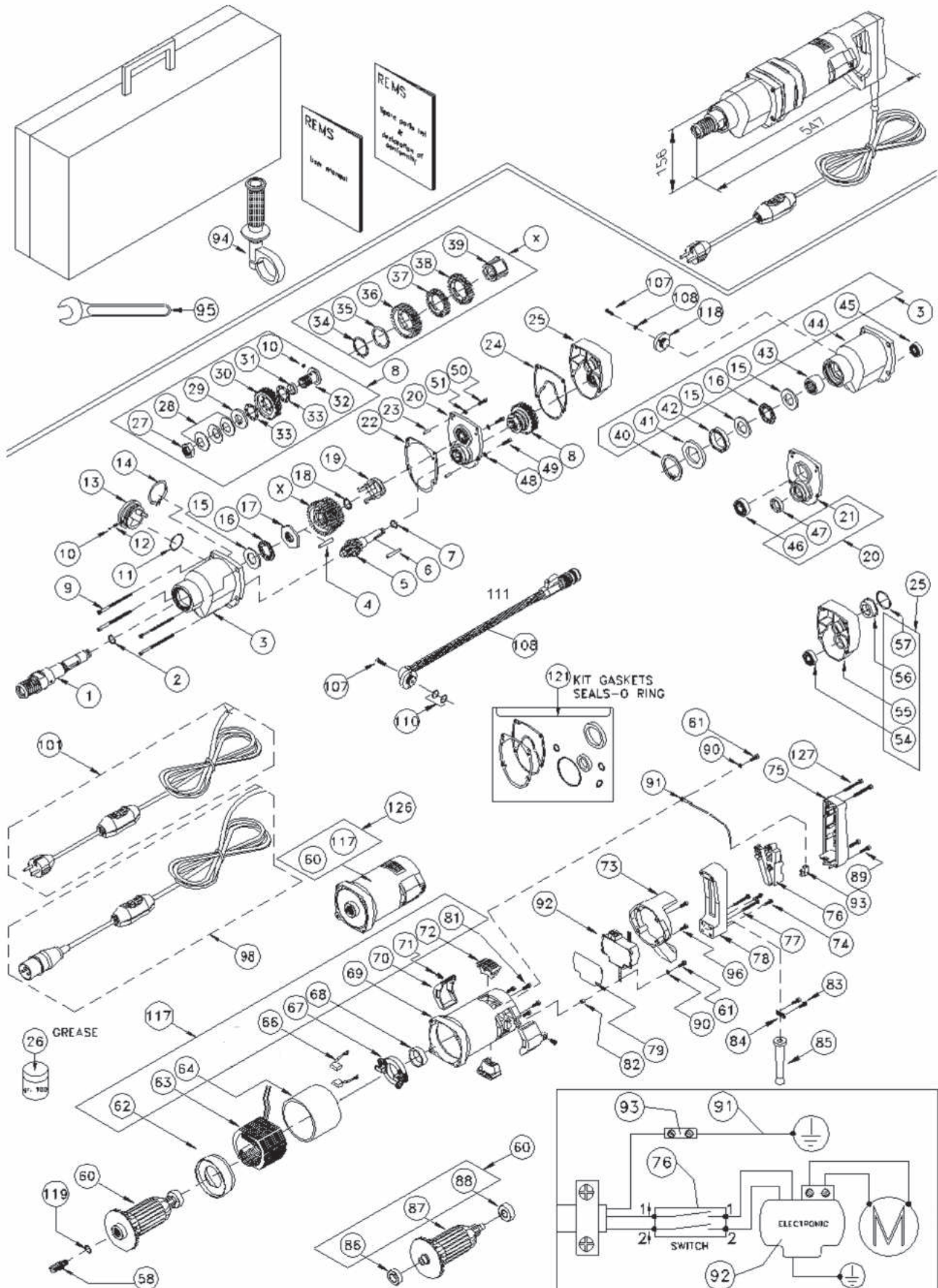



## REMS Picus S3

deu	eng	fra	ita	
1 Antriebsspindel	Drive spindle	Arbre	Mandrino motore	180177
2 O-Ring	O-ring	Joint torique	O-ring	060308
3 Getriebegehäuse kompl.	Gear housing	Carcasse compl.	Scatola ingranaggi completa	180182
4 Zylinderstift	Straight pin	Tige cylindrique	Spina cilindrica	088208
5 Kupplungsspindel	Clutch spindle	Abre d'embrayage	Mandrino frizione	180180
6 Stift	Straight pin	Tige cylindrique	Spina cilindrica	088048
7 O-Ring	O-ring	Joint torique	O-ring	060314
8 Rutschkupplung kompl. Pos. 27–33 und 10	Slipping clutch complete Pos. 27–33 and 10	Embrayage complet Pos. 27–33 et 10	Frizione completa Pos. 27–33 e 10	180172
9 Zylinderschraube	Fillister head screw	Vis tête cylindrique	Vite a testa cilindrica	081144
10 Stahlkugel	Steel ball	Bille d'acier	Sfera di acciaio	057047
11 O-Ring	O-ring	Joint torique	O-ring	060299
12 Druckfeder	Pressure spring	Ressort de compression	Molla di compressione	180197
13 Getriebeumschalter	Gear switch	Sélecteur de vitesse	Invertitore ingranaggio	180165
14 Sicherungsring	Locking ring	Circlip	Rondella di sicurezza	059149
15 Laufscheibe	Washer	Rondelle	Ranella	057104
16 Axial-Nadelkranz	Axial needle collar	Cage à aiguilles axiale	Gabbia assiale a rullini	057103
17 Spindelmutter	Spindle nut	Ecrou	Dado del mandrino	180188
18 Sicherungsring	Locking ring	Circlip	Rondella di sicurezza	059154
19 Ziehkeil	Draw key	Clavette	Chiave	180181
21 Zwischenflansch ohne Lager	Intermediate flange	Flasque intermédiaire	Flangia intermedia s. cuscin.	180174
22 Getriebegehäusedichtung	Gear housing seal	Joint carcasse d'entr.	Guarnizione scatola ingranaggi	180189
25 Motorflansch kompl. Pos. 54–57	Motor flange complete Pos. 54–57	Flasque moteur Pos. 54–57	Flangia motore completa Pos. 54–57	180176
26 Getriebefett	Gear flow grease	Graisse à engrenages	Grasso ingranaggi	091002 R0,5
30 Kupplungszahnrad	Toothed gear wheel	Roue dentée	Ingranaggio della frizione	180203
34 Sicherungsring	Locking ring	Circlip	Rondella di sicurezza	059150
35 Scheibe	Washer	Rondelle	Ranella	086056
36 Zahnrad	Toothed wheel	Engrenage	Ruota dentata	180183
37 Zahnrad	Toothed wheel	Engrenage	Ruota dentata	180184
38 Zahnrad	Toothed wheel	Engrenage	Ruota dentata	180185
39 Schaltnabe	Gear cam	Moyeu	Mozzo commutatore	180186
40 Sicherungsring	Locking ring	Circlip	Rondella di sicurezza	059151
41 Wellendichtring	Rotary shaft seal	Joint pour arbre	Anello guarnizione ondulata	060309
42 Wellendichtring	Rotary shaft seal	Joint pour arbre	Anello guarnizione ondulata	060310
43 Nadellager	Needle bearing	Roulement à aiguilles	Cuscinetto a rullini	057180
44 Getriebegehäuse o. Lager	Gear housing w/o bearing	Carcasse	Scatola ingranaggi senza cusc.	180194
45 Rillenkugellager	Grooved ball bearing	Roulement à billes	Cuscinetto a sfere	057005
46 Rillenkugellager	Grooved ball bearing	Roulement à billes	Cuscinetto a sfere	057085
47 Wellendichtring	Rotary shaft seal	Joint pour arbre	Anello guarnizione ondulata	060311
50 Zylinderschraube	Fillister head screw	Vis tête cylindrique	Vite a testa cilindrica	081148
51 Sicherungsscheibe	Locking washer	Rondelle de sécurité	Rondella di sicurezza	059088
56 Filzring	Felt ring	Anneau en feutre	Annello feltro	180192
57 O-Ring	O-ring	Joint torique	O-ring	060302
58 Ankerritzel	Rotor pinion	Pignon	Pignone indotto	180187
60 Anker kompl. mit Lager	Rotor complete with bearing	Induit avec roulement	Indotto completo c. cuscinetto	180512 R220
61 Linsenschraube	Oval head screw	Vis tête fraisée bombée	Vite a testa svasata con perno	083151
63 Stator	Stator	Stator	Statore	180514 R220
64 Schutzisolierung	Protective insulation	Isolant de protection	Guarnizione di protezione	180506
66 Kohlebürste Paar	Carbon brushes pack of 2	Balais de charbon, jeu 2p.	Carboncini, conf. 2 pz.	180511 R220
67 Kohlehalteplatte mit Feder	Carbon holder plate w. spring	Support balais avec ressort	Portacarboncini con molla	180204
68 Dämmring	Insulating ring	Anneau isolant	Anello isolante	180518
69 Motorgehäuse	Motor housing	Carcasse moteur	Alloggiamento motore	180515
70 Deckel	Cover	Couvercle	Coperchio	180516
71 Linsenschraube	Oval head screw	Vis tête fraisée bombée	Vite a testa svasata con perno	083128
72 Lüftungsdeckel	Venting cover	Couvercle ventilateur	Coperchio ventilatore	180508
Motorgriff komplett — Pos. 73–75, 77, 78, 89, 96 und 127	Motor handle complete Pos. 73–75, 77, 78, 89, 96 and 127	Poignée complète Pos. 73–75, 77, 78, 89, 96 et 127	Impugnatura motore completa Pos. 73–75, 77, 78, 89, 96 e 127	180501
76 Schalter	Switch	Interrupteur	Interruttore	180502

## REMS Picus S3

	deu	eng	fra	ita	
	ab Maschinenummer 003412 Motorgriff komplett Pos. 73–75, 77, 78, 89, 96 und 127	from machine number 003412 Motor handle complete Pos. 73–75, 77, 78, 89, 96 and 127	à partir de la machine n° 003412 Poignée complète Pos. 73–75, 77, 78, 89, 96 et 127	da matricola 003412 Impugnatura motore completa Pos. 73–75, 77, 78, 89, 96 e 127	180131 R
76	ab Maschinenummer 003412 Schalter	from machine number 003412 Switch	à partir de la machine n° 003412 Interrupteur	da matricola 003412 Interruttore	180132 R
79	Isolierfolie	Insulating foil	Film isolant	Pellicola d'isolamento	180505
85	Kabeltülle	Cable bush	Passe-fil	Guaina cavo	180175
86	Rillenkugellager	Grooved ball bearing	Roulement à billes	Cuscinetto a sfere	057112
88	Rillenkugellager	Grooved ball bearing	Roulement à billes	Cuscinetto a sfere	057064
92	Elektronik	Electronic	Electronique	Elettronica	180503 R220
92	Elektronik	Electronic	Electronique	Elettronica	180503 R110
94	Gegenhalter	Steady	Contre poignée	Maniglia	180167 R
95	Einmaulschlüssel SW 32	Spanner SW 32	Clé plate SW 32	Chiave a forcina sempl. SW 32	079002
101	Anschlussleitung 230V	Connecting cable 230 V	Raccordement 230 V	Cavo d'allacciamento 230 V	030076 R220
107	Zylinderschraube	Fillister head screw	Vis tête cylindrique	Vite a testa cilindrica	081007
110	O-Ring	O-ring	Joint torique	O-ring	060303
111	Wasserzuführeinrichtung Pos. 107, 108, 110	Water connecting device Pos. 107, 108, 110	Dispositif d'amenée d'eau Pos. 107, 108, 110	Disp. alimentazione acqua Pos. 107, 108, 110	180169
116	O-Ring	O-ring	Joint torique	O-ring	060313
118	Deckel	Cover	Couvercle	Coperchio	180179
119	O-Ring	O-ring	Joint torique	O-ring	060313
121	Dichtungssatz	Seal kit	Set de joints, jeu	Assortimento guarnizioni, set	180166

## REMS Picus S2/3,5

### Teilverzeichnis

Aktueller Stand  
siehe [www.rems.de](http://www.rems.de)  
weitere Teile auf Anfrage

### Spare parts list

Latest version  
see [www.rems.de](http://www.rems.de)  
other parts on request

### Liste des pièces

Situation actuelle  
voir [www.rems.de](http://www.rems.de)  
autres pièces sur demande

### Elenco dei pezzi

Ultimo aggiornamento  
vedi [www.rems.de](http://www.rems.de)  
altri ricambi su richiesta

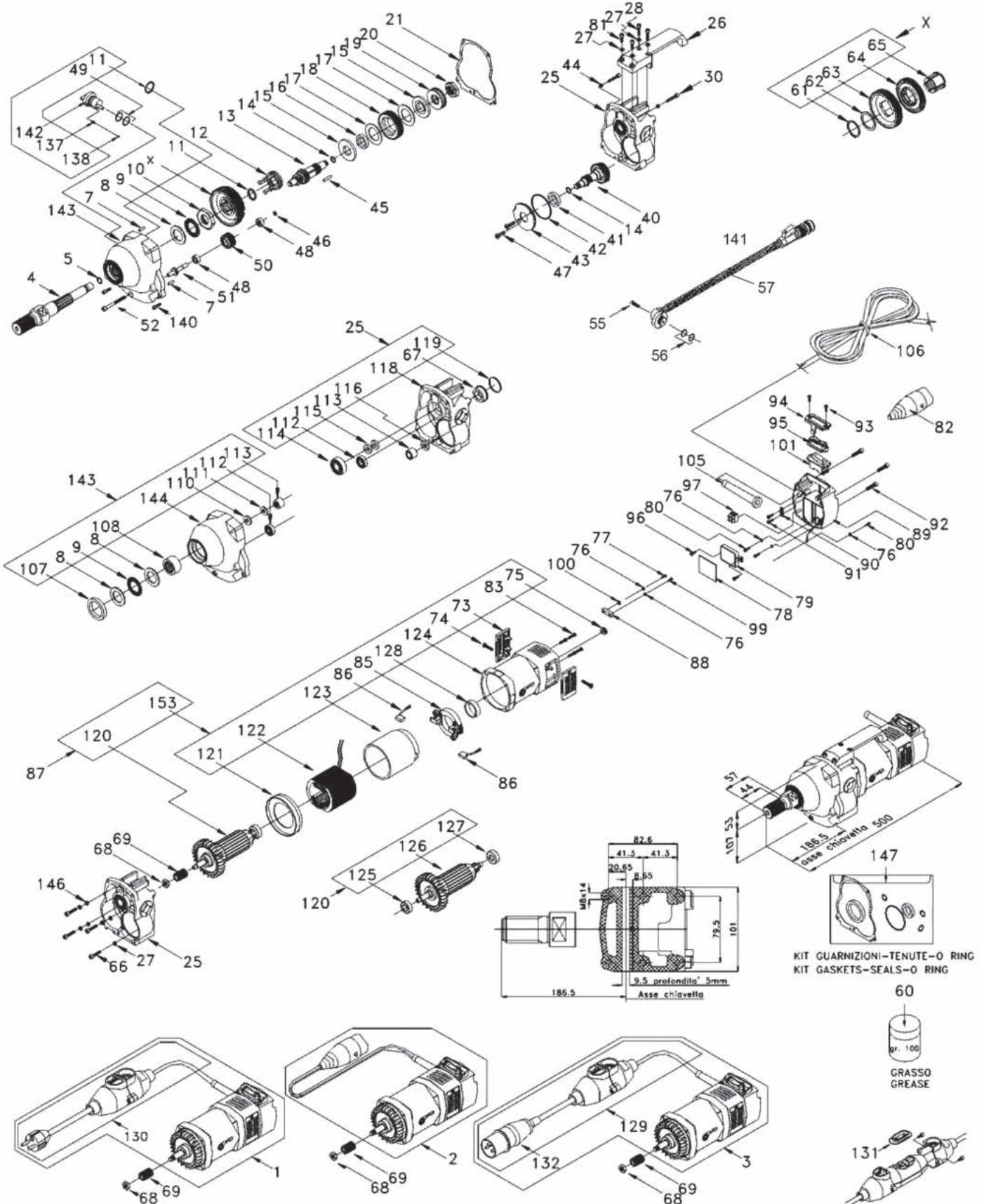

## REMS Picus S2/3,5

deu	eng	fra	ita	
1 Motor kompl. mit Leitung	Motor complete with lead	Moteur complet	Motore completo con cavo	180500R220
4 Antriebsspindel	Drive spindle	Arbre	Mandrino motore	180198
5 O-Ring	O-ring	Joint torique	O-ring	060308
8 Laufscheibe	Running washer	Rondelle	Anello di scorrimento	057189
9 Axial-Nadelkranz	Axial needle collar	Cage à aiguilles axiale	Gabbia assiale a rullini	057146
10 Sechskantmutter	Hexagon nut	Ecrou six pans	Dado esagonale	085064
11 Sicherungsring	Locking ring	Circlip	Anello di sicurezza	059160
12 Ziehkeil	Wedge	Cale	Cuneo	180219
13 Kupplungsspindel	Clutch spindle	Arbre d'embrayage	Mandrino della frizione	180210
14 O-Ring	O-ring	Joint torique	O-ring	060314
15 Scheibe	Washer	Rondelle	Disco	180211
16 Bronzering	Brass ring	Anneau en bronze	Anello in bronzo	180212
17 Kupplungsscheibe	Clutch washer	Rondelle d'embrayage	Disco frizione	180213
18 Kupplungszahnrad	Toothed gear wheel	Roue dentée	Ruota dentata frizione	180229
19 Tellerfeder	Cup spring	Ressort Belleville	Molla a disco	061088
20 Sechskantmutter	Hexagon nut	Ecrou hexagonal	Dado esagonale	085062
21 Dichtung	Seal	Joint	Guarnizione	180199
25 Hinteres Getriebegehäuse kompl.	Rear gear housing compl.	Carcasse arrière compl.	Carcassa ingran. post. compl.	180220
26 Griff	Handle	Poignée	Impugnatura	180507
27 Scheibe	Washer	Rondelle	Piastra	086048
30 Zylinderschraube	Fillister head screw	Vis tête cylindrique	Vite a testa cilindrica	081139
34 Federring	Spring washer	Rondelle élastique	Ranella elastica	087025
38 Anschluss	Connection	Raccordement Picus	Congiunzione	180209R
40 Zwischenspindel	Intermediate spindle	Arbre	Mandrino intermedio	180224
41 Wellendichtring	Rotary shaft seal	Joint pour arbre	Anello guarnizione ondulata	060360
42 O-Ring	O-ring	Joint torique	O-ring	060361
45 Zylinderstift	Straight pin	Tige cylindrique	Spina cilindrica	088052
46 Sicherungsring	Locking ring	Circlip	Anello di sicurezza	059165
48 Rillenkugellager	Grooved ball bearing	Roulement à billes	Cuscinetto a sfere	057192
49 O-Ring	O-ring	Joint torique	O-ring	060316
50 Zahnrad	Toothed wheel	Roue dentée	Ruota dentata	180225
52 Zylinderschraube	Fillister head screw	Vis à tête cylindrique	Vite a testa cilindrica	083201
59 O-Ring	O-ring	Joint torique	O-ring	060313
60 Getriebefett	Gear flow grease	Graisse à engrenages	Grasso ingranaggi	091002R0,5
61 Sicherungsring	Locking ring	Circlip	Rondella di sicurezza	059150
62 Scheibe	Washer	Rondelle	Ranella	086056
63 Zahnrad	Toothed wheel	Roue dentée	Ruota dentata	180228
64 Zahnrad	Toothed wheel	Roue dentée	Ruota dentata	180226
65 Nabe für Ziehkeil	Hub for pull key	Moyeu	Mozzo p.chiavetta Picus	180215
66 Zylinderschraube	Cylinder screw	Vis tête cylindrique	Vite cilindrica	081154
67 Filzring	Felt ring	Anneau en feutre	Annelo feltro	180192
68 Sechskantmutter	Hexagon nut	Ecrou hexagonal	Dado esagonale	085008
69 Ankerritzel	Anchor cog	Pignon	Ruota dentata	180527
73 Kohleabdeckung	Carbon cover	Protection balais	Copertura carbone	180223
74 Zylinderschraube	Fillister head screw	Vis tête cylindrique	Vite a testa cilindrica	081140
79 Elektronikvorrichtung	Electronic device	Dispositif électronique	Dispositivo elettronico	180523
85 Kohlehalteplatte mit Feder	Carbon holder plate w. spring	Support balais avec ressort	Portacarboncini con molla	180204
86 Kohlebürsten Paar	Carbon brushes pair	Balais de charbon, jeu 2p.	Carboncini, conf. 2 pz.	180576R220
87 Motorblock	Motor block	Bloc moteur	Blocco motore	180522R220
89 Schalteraufnahme	Switch holder	Interrupteur	Alloggiamento interruttore	180524
101 Schalter	Switch	Interrupteur	Interruttore	180528
105 Kabeltülle	Cable bush	Passe-fil	Guaina cavo	180175
107 Wellendichtring	Rotary shaft seal	Joint pour arbre	Anello guarnizione ondulata	060315
118 Hinteres Getriebegehäuse	Rear gear housing	Carcasse arrière	Carcassa ingranaggio post.	180221
119 O-Ring	O-ring	Joint torique	O-ring	060302
120 Anker mit Lüfter	Rotor with ventilator	Induit avec ventilateur	Indotto con ventilatore	180520R220
122 Stator	Stator	Stator	Statore	180521R220
127 Rillenkugellager	Grooved ball bearing	Roulement à billes	Cuscinetto a sfere	057064
128 Dämmring	Insulating ring	Anneau isolant	Anello isolante	180518
137 Druckfeder	Pressure spring	Ressort de compression	Molla di compressione	180197
138 Stahlkugel	Steel ball	Bille d'acier	Sfera di acciaio	057047
141 Wasserzuführinrichtung	Water connecting device	Dispositif d amenée d'eau	Disp. alimentazione acqua	180169

## REMS Picus S2/3,5

deu	eng	fra	ita	
142 Getriebeumschalter	Gear shift	Commutateur	Invertitore ingranaggio	180200
143 Getriebegehäuse vorn kompl.	Front gear housing complete	Carcasse avant compl.	Carcassa ingran. ant. compl.	180222
147 Dichtungssatz	Seal kit	Set de joints, jeu	Assortimento guarnizioni, set	180214
129 Anschlussleitung 230 V	Connecting cable 230 V	Raccordement 230 V	Cavo d'allacciamento 230 V	030076 R220 130
146 Scheibe	Washer	Rondelle	Piastra	086049
148 Motorplatte	Motor plate	Plaque moteur	Piastra motore	180014